



Model 2256-ALN Phase Locked Oscillator



The Model 2256-ALN is a single frequency, very low Phase Noise PLL unit that can be used to replace your unstable microwave crystal oscillator chain with a stable constant frequency. With the Model 2256-ALN and a very accurate 10 MHz or 100 MHz reference, a frequency stability of 1 part in 10^{-7} is possible with a TCXO (temperature controlled crystal oscillator), or using an OCXO (oven controlled crystal oscillator), stability's on the order of 1 part in 10^{-10} are possible. Of course, using a Rubidium Oscillator can provide a stability of 1 part in 10^{-12} . Using a standard off-the-shelf crystal oscillator can provide 1 part in 10^{-6} if a careful circuit is designed, or purchased from a standard crystal oscillator manufacture. A built-in Reverse voltage protection is a standard feature used to protect the Model 2256-ALN from an improper voltage polarity.

Each unit is in an RF tight enclosure to provide the best possible suppression of stray RF leakage essential to quiet Local Oscillator operation.

Typical uses for this PLL are Local Oscillators for Microwave Receivers, Transmitters and Transverters for the Amateur Radio 10 GHz frequency band when used with a 144 MHz Intermediate Frequency. This unit is also designed to replace the Local Oscillator chain in the DB6NT Transverter unit using the last times (4) multiplier stage.

NOTE: *It will be necessary to put an attenuator ranging from 8 to 10 dB on the output before connecting it to the last multiplier stage of the DB6NT transverter. Otherwise, damage may occur to the multiplier stage as a result of too much RF drive from the Model 2556-ALN PLL unit.*

Product Specifications

Specification	Conditions	Values		
		MIN	TYP	MAX
Input Voltage		+10.7V	+13.5V	+20.0V
Input Current			140 ma	160 ma
RF Impedance		50 ohms		
RF Output Power	Into a 50 ohm RF load	+17 dBm	+18 dBm	
Phase Noise (typical)	Dual 2556-ALN's with mixer and an HP 3585A Spectrum Analyzer	-90 dBc/Hz @ 1 KHz -115 dBc/Hz @ 10 KHz -126 dBc/Hz @ 100 KHz		
Harmonic Output	2 nd and 3 rd order harmonics related to fundamental frequency		> -20 dBc	
Frequency Options		1 (2256MHz)		
Reference Frequency	External. reference provided by customer	10 MHz or 100MHz Typically 0.5 to 1 v p-p		
Lock Output Voltage (open circuit)	Unit in Phase Lock, current limited through internal 1K ohm series resistor	5 Volts		
Lock Output Current		2 ma		
Temperature Range	None condensing conditions	-20 C	--	+80 C
Factory Warranty	Under normal use, no intentional damage found	1 Year, Full Replacement if no intentional damage found		

Power Supply Requirements

The Model 2256-ALN is rated for a power supply voltage of between +10.7 Vdc and +20.0 Vdc, the typical voltage being +13.5Vdc. This supply voltage ***must be very clean*** so the PLL unit will operate correctly. If you find the Model 2256-ALN producing spurious noise or wideband noise after it is turned on, please examine your power supply voltage with a high bandwidth oscilloscope. Make sure there is no noise or garbage above 100 millivolts, or there is no voltage dropout below +10.7 volts. If there is, please provide the proper filtering or extra voltage as needed to correct the problem. The Model 2256-ALN will only provide as clean a signal as your supply voltage will allow. ***THIS IS VERY IMPORTANT.***

Reference Frequency Requirements

A word of caution regarding the input level to the Reference Input port on the Model 2256-ALN; if the input level is too high, meaning greater than 1.5 v p-p or higher, the phase locked oscillator may generate spurs due to over-clocking of the internal reference counter. You should measure the output level of your reference oscillator on an oscilloscope to verify that the output level, terminated into a 50 Ohm load, is between 0.5 to 1 volt peak to peak. Either a square wave or sine wave can be used. ***THIS IS VERY IMPORTANT.***

Reference Frequency Selection Information

The Model 2256-ALN will accept either a 10MHz or 100MHz external reference input by selecting the appropriate reference option jumper inside the unit. The jumper options are listed in the Table 2.

Table 2 – Reference Frequency Options

Jumper – JP2	Reference Input Frequency
“4”	
O	10 MHz
S	100 MHz

O = Jumper Removed, S = Jumper Installed

Opening the Model 2256-ALN to change Reference Frequency Options is accomplished by removing the six (6) 0-80 Phillips head screws from the top cover. These screws are very small so put them in a safe place until time to put them back. After the cover is opened, you will notice there are (4) four jumper options (JP2) in the upper left corner next to the reference-input port. *See figure 1 below.* There is only one jumper shunt included with the unit as shipped, and jumper positions 1,2 and 3 are not used on the Model 2256-ALN.

The Model 2256-ALN is shipped with JP2-4 OPEN for a 10MHz external reference input. To select the 100MHz external reference input option, place the jumper shunt provided onto jumper position #4, shorting it together as described in table 2.

Remember the “**O**” is for **OPEN** (no jumper installed), and “**S**” is for **SHORTED** (jumper installed). The jumper layout is shown in Figure 1. Changing a jumper will automatically select the new reference frequency option and will not require the unit to be power cycled.

NOTE: The ISP jumper (JP1) is not for customer use and is only for programming the on-board microprocessor. **DO NOT PUT ANY JUMPERS ON JP1.**

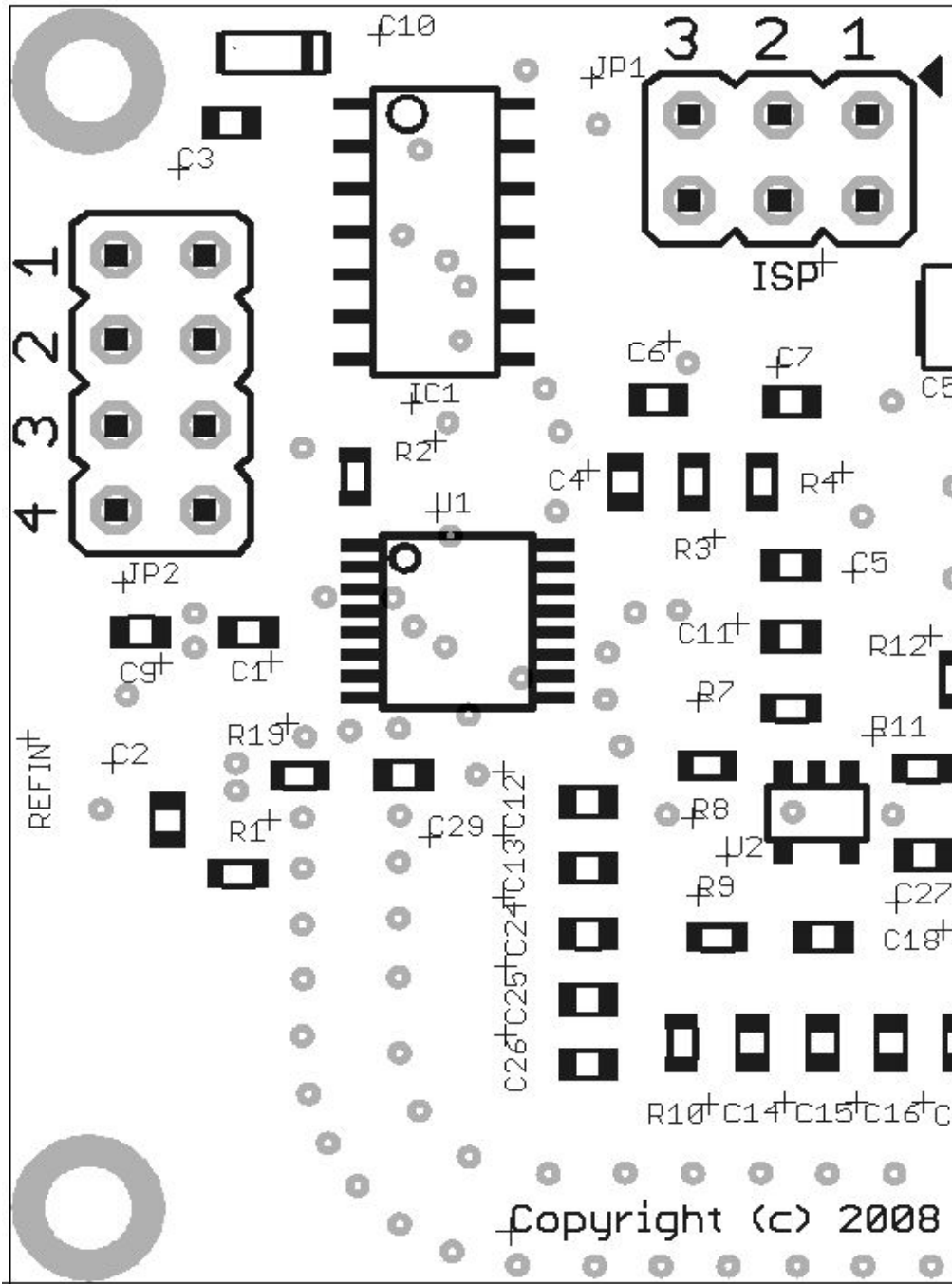

Figure 1

Customer External Connections

Connection	Function
RFout SMA	Oscillator RF Output port
REFin SMA	10 / 100 MHz Reference Oscillator input
Vin	+13.5 Vdc @ 140ma. typical (<i>reverse voltage protected</i>)
GND	Chassis Ground Terminal
Lock	Lock Indicator output signal (Digital signal)

Lock Indicator Output connection

The Lock Output pin (Lock) connection can be used for several things. For example;

- 1.) Front panel indication that PLL is in locked or unlocked state.
- 2.) Signal switch for shutting down a Transmitter while an “out of lock” state exists.
- 3.) Signal switch for quieting a receiver audio section while an “out of lock” state exists.
- 4.) Both a front panel indication and a shutdown switch for a Receiver or Transmitter.

A lock condition is indicated by a “**High**” level on the Lock pin. A “**Low**” level indicates the unlocked condition.

Note: An external circuit is necessary to use the Lock Output signal, and can be a combination of Analog or Digital circuits. The Lock Output pin is capable of driving up to 2 digital 74LS TTL loads if needed.

Example 1 shows how to utilize the Lock pin to control a front panel LED lock indicator.. The LED will light when in the locked state, and will be out when in the unlocked state.

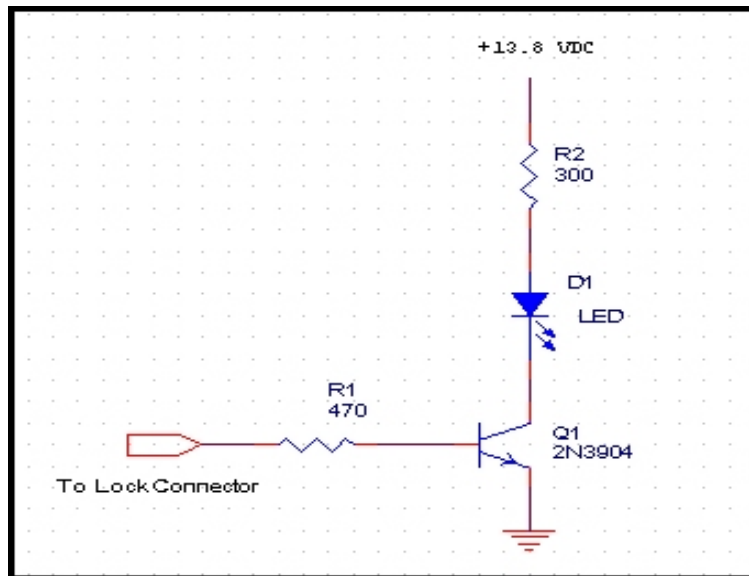

Example 1

Example 2 shows an NPN transistor switch to control a load such as a relay or a circuit used to enable a transmitter section by grounding the transmit enable. The 2N3904 is a generic transistor, and any common transistor capable of operating safely in your circuit should work here.

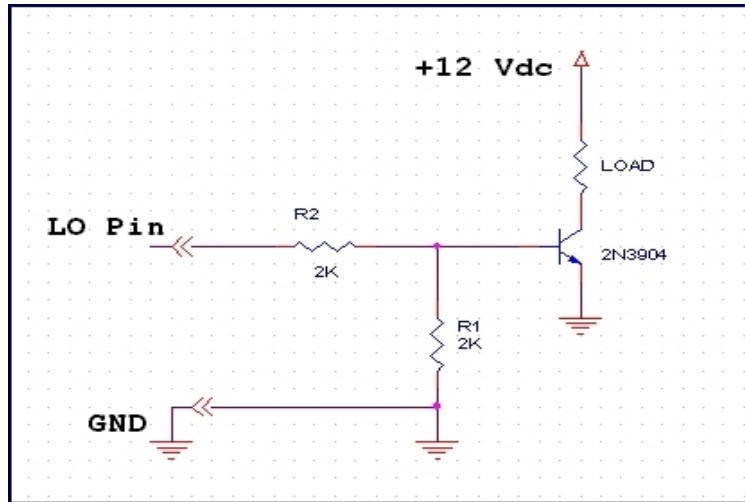

Example 2

Warranty

All JWM Engineering Group, Inc. products are warranted against defects in materials and workmanship. This warranty applies for one year from the date of delivery. JWM Engineering Group, Inc. will repair or replace products that prove to be defective during the warranty period, provided they are returned to JWM Engineering Group, Inc. No other warranty is expressed or implied. JWM Engineering Group, Inc. is not liable for any consequential damages.

A return material authorization (RMA) is required before returning a product for repair or replacement. Contact JWM Engineering Group, Inc. at the contact information provided below.

Contact Information

JWM Engineering Group, Inc.
9 Westchester Court
Trabuco Canyon, CA 92679
949-713-6367
<http://www.jwmeng.com>

Disclaimer

JWM Engineering Group, Inc. does not assume any responsibility for use of any circuit described, no circuit patents licenses are implied and JWM Engineering Group, Inc. reserves the right at any time without notice to change said circuitry and specifications.

Mounting Base Plate Information

